



AMFW110-NZ



Picture is coming soon

Encapsulated

Aimtec's new AMFW110-NZ series of EMC filters can help improve the EMC compliance of your system and are designed to meet the CISPR32/EN55032 and IEC/EN61000-4 standards. They have an input voltage range of 66-160VDC and are also designed to meet the EN50155 railway standard making them ideal for both onboard and trackside applications.

With a high efficiency of 98% and the availability of different mounting options, the AMFW110-NZ series is an easy plug and play EMC improvement solution.

Features



- Ultra-Wide Input: 66 - 160VDC
- Operating Temp: -40 °C to +85 °C
- High isolation voltage: 1500VAC
- Input Over-voltage Protection
- EMC meets CISPR32/EN55032 & IEC/EN61000-4 Series Standard

Summary

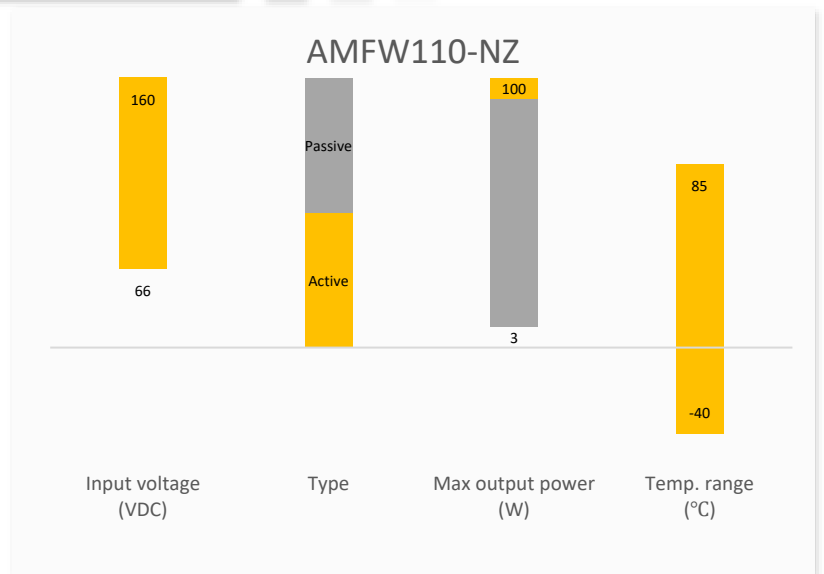

Training

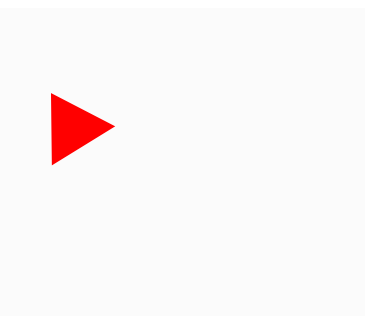

Product Training Video
(click to open)

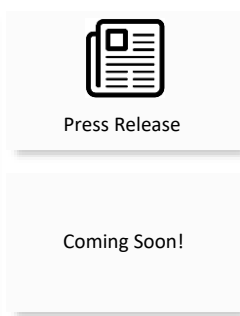

Application Notes

Applications



Power Grid



Industrial



Telecom



Instrumentation

Models & Specifications

Models

Model	Input Voltage (VDC)	Max output power (W)
AMFW110-0.9NZ	66 ~ 160	100

Note: Use suffix "ST" for chassis mounting (ex. AMFW110-0.9NZ-ST) is chassis mounting version).

Input Specifications

Parameters	Tested Conditions	Typical	Maximum	Units
Input Voltage		110	160	VDC
No-load Current	110VDC	4		mA

Output Specifications

Parameters	Tested Conditions	Typical	Maximum	Units
Max Output Voltage Limit	Input voltage is not more than 175V	165		VDC

NOTE: Continuous operation of the filters at their Max. Output voltage Limit may cause failures or permanent damage.

General Specifications

Parameters	Conditions	Typical	Maximum	Units
Efficiency	110VDC, Full load	98		%
Operating temperature		-40 to +85		°C
Storage temperature		-55 to +105		°C
Case temperature rise	110VDC, Full load	+25		°C
Isolation Voltage (+Vin / GND)	< 5mA leakage current		1500	VAC
Humidity			95	%RH
Case material	Heat resistant black Plastic (flammability to UL 94V-0)			
Weight	PCB mountable models	60		g
	With optional -ST mounting plate	80		
Dimensions (L x W x H)	PCB mountable models	2.12 x 1.13 x 0.93 inches (53.80 x 28.80 x 23.50mm)		
	With optional -ST mounting plate	2.99 x 1.24 x 1.27 inches (76.00 x 31.50 x 32.30mm)		
MTBF	>1,000,000 hrs (MIL-HDBK -217F, t=+40°C)			

NOTE: All specifications in this datasheet are measured at an ambient temperature of 25°C, humidity<75%, nominal input voltage and at rated output load unless otherwise specified.

Safety Specifications

Parameters		
Standards	EMC - Conducted and radiated emission	CISPR32 / EN55032, class B
	Electrostatic Discharge Immunity	IEC 61000-4-2 Contact ±6KV / Air ±8KV, Criteria B
	RF, Electromagnetic Field Immunity	IEC 61000-4-3 10V/m, Criteria A

Electrical Fast Transient/Burst Immunity	IEC 61000-4-4 ±2KV, Criteria B
Surge Immunity	IEC 61000-4-5 ±2KV(2Ω internal) / ±4KV(12Ω internal), Criteria B EN50155 ±1.8KV(5Ω internal), Criteria B
RF, Conducted Disturbance Immunity	IEC 61000-4-6 10Vr.m.s, Criteria A
Voltage interruption	EN50155 100% ~ 0%,10ms, Criteria A

Dimensions

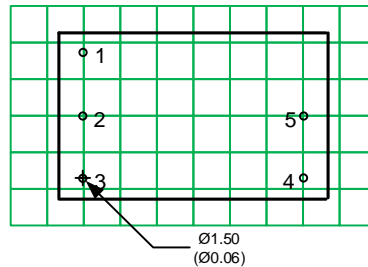
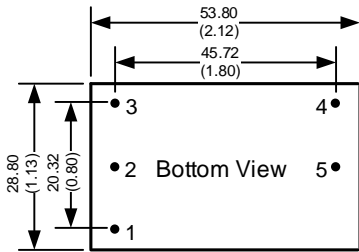

Pin Output Specifications	
Pin	Single
1	GND
2	+V Input
3	-V Input
4	-V Output
5	+V Output

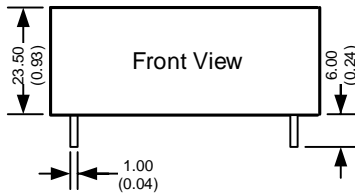

Dimensions mm (inch).
Pin diameter tolerance ± 0.1 (± 0.004)
Pin height tolerance ± 0.5 (± 0.02)

Dimensions with ST Optional

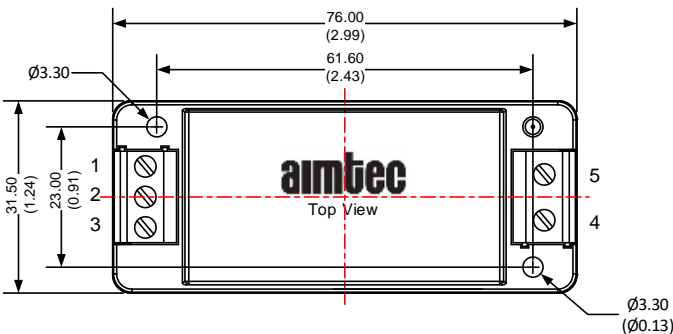

Pin Output Specifications	
Pin	Single
1	GND
2	+V Input
3	-V Input
4	-V Output
5	+V Output

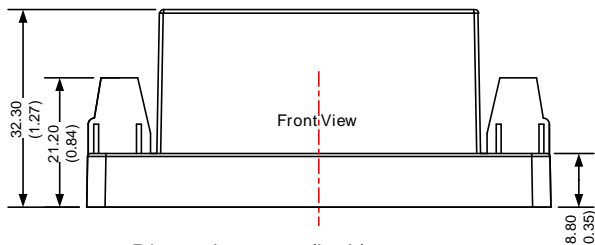

Dimensions mm (inch)
Wire range: 24-12 AWG
General tolerances ± 0.50 (± 0.02)

Application Circuit

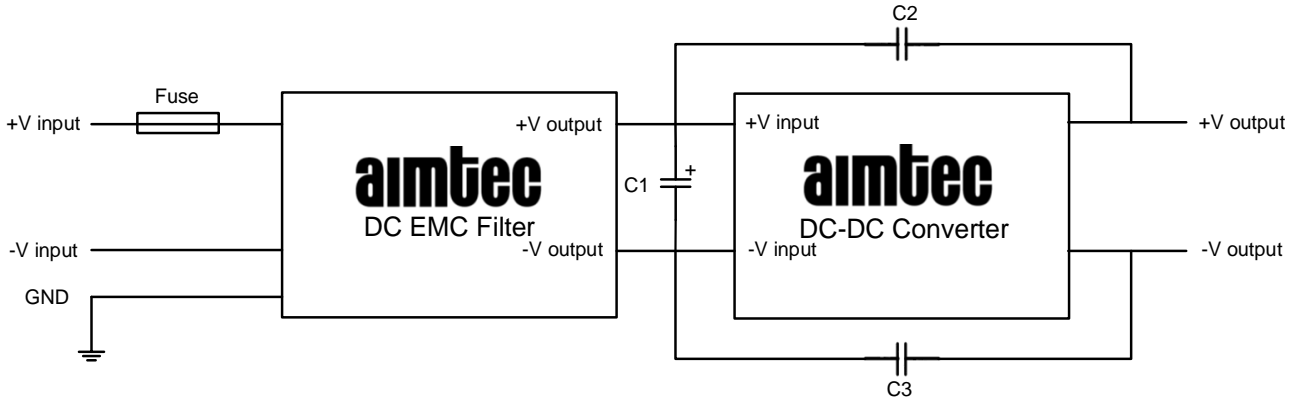

Model	Recommended external circuit parameters
C1	82uF/200V electrolytic capacitor
C2 / C3	2200pF/400VAC capacitor
Fuse	The fuse value varies with different power modules and must be selected in accordance with the specified input current of the corresponding power converter, but not exceeding the filter specifications.

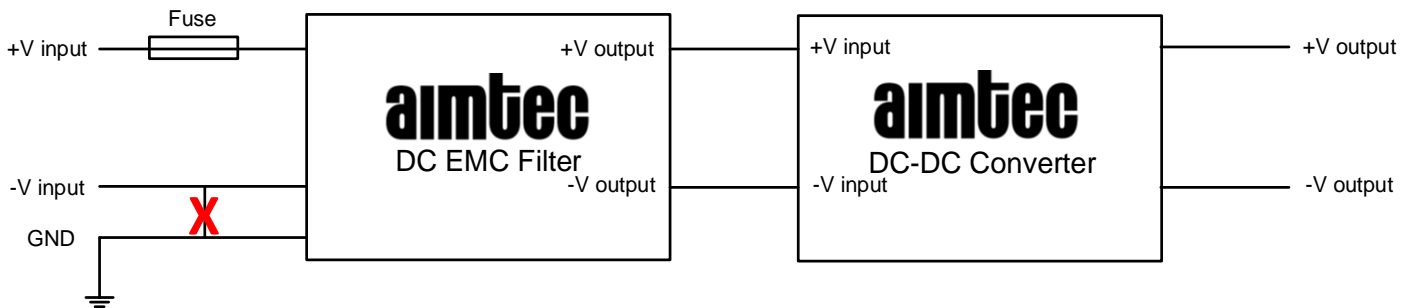
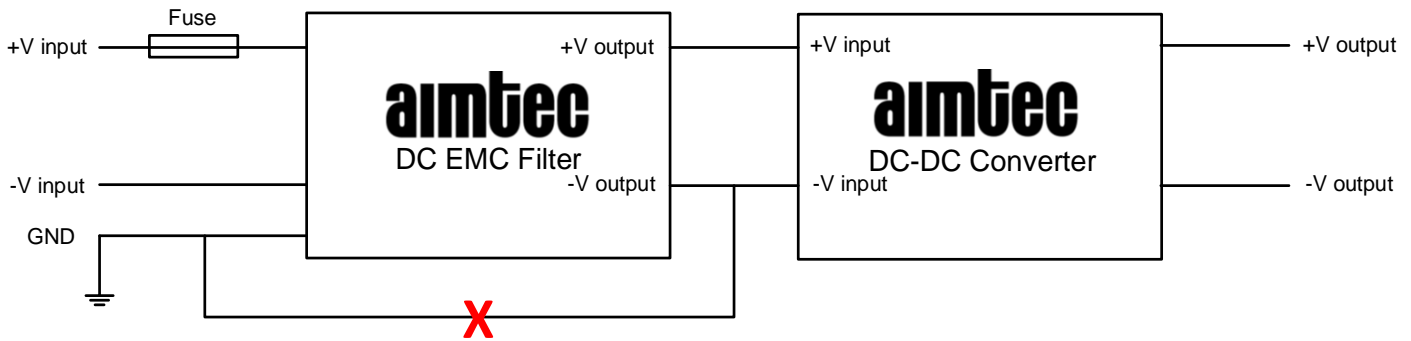

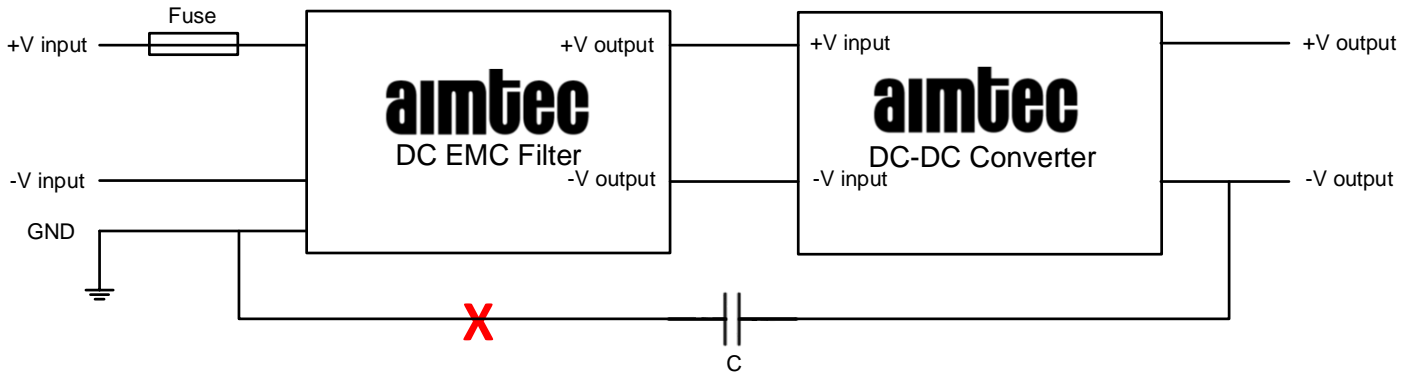

Note: Connections marked with **X** interfere with this filter modules performance and should therefore not be used

NOTE: 1. Datasheets are updated as needed and as such, specifications are subject to change without notice. Once printed or downloaded, datasheets are no longer controlled by Aimtec; refer to www.aimtec.com for the most current product specifications. **2.** Product labels shown, including safety agency certifications on labels, may vary based on the date manufactured. **3.** Mechanical drawings and specifications are for reference only. **4.** All specifications are measured at an ambient temperature of 25°C, humidity<75%, nominal input voltage and at rated output load unless otherwise specified. **5.** Aimtec may not have conducted destructive testing or chemical analysis on all internal components and chemicals at the time of publishing this document. CAS numbers and other limited information are considered proprietary and may not be available for release. **6.** This product is not designed for use in critical life support systems, equipment used in hazardous environments, nuclear control systems or other such applications which necessitate specific safety and regulatory standards other the ones listed in this datasheet. **7.** Warranty is in accordance with Aimtec's standard Terms of Sale available at www.aimtec.com.