

Typical Application of Dual Separated Output DC/DC Converters for RS-485 Communications

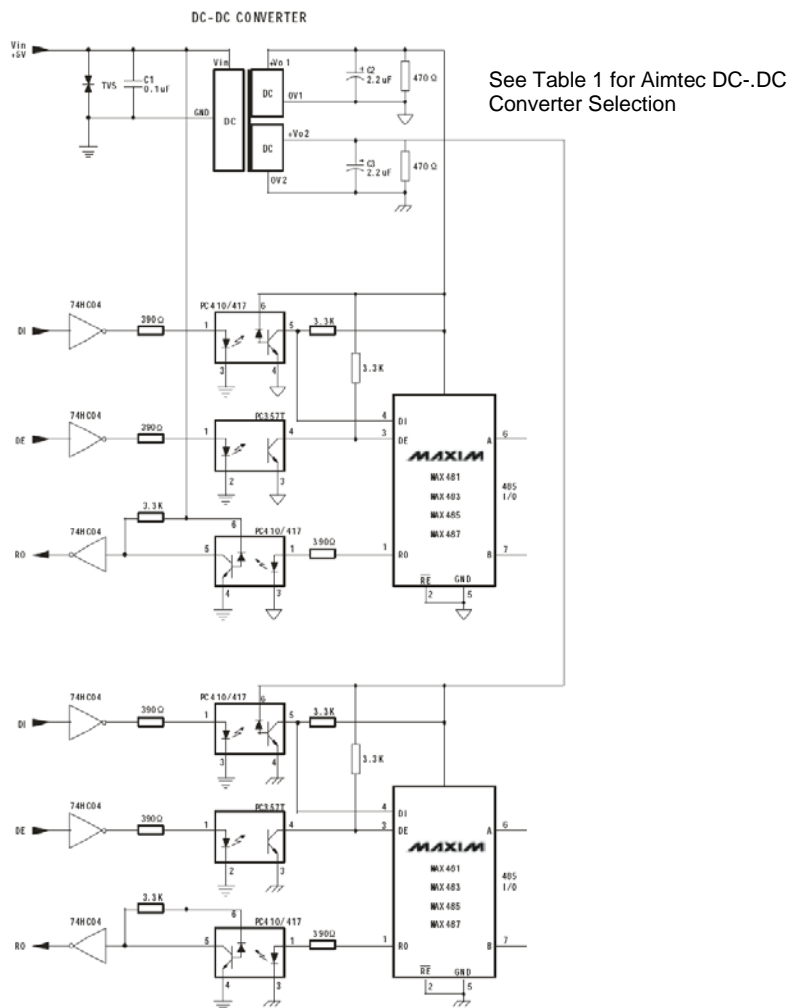

MAXIM to Analog Devices Inc. equivalent models	
Maxim	Analog Devices Inc
MAX481	ADM4852
MAX483	ADM483
MAX485	ADM485
MAX487	ADM4851

Dual Separated Output DC-DC converters apply dual galvanic isolation, in addition to photoelectric isolation that aids in EMI suppression, elimination of ground loops and provides immunity to the system from external interference.

System Input Voltage	Input-Output Isolation	Power consumption, 1W	
		Unregulated output	
		Model	Case
5VDC	1000VDC	AM1D-050505DZ	SIP7
		AM1P-050505DZ	DIP8
12VDC	1000VDC	AM1D-120505DZ	SIP7
		AM1P-120505DZ	DIP8
24VDC	1000VDC	AM1D-240505DZ	SIP7
		AM1P-240505DZ	DIP8

NOTE: The external capacitors (C2, C3) connected to the converter's output are normally a maximum value of 10µF. The external resistances (R2/R3) connected to the converter output should be chosen according the following rule: the power consumption of R2/R3 is equal to 2~5% of the converter's rated output power.

Notes: Information furnished is believed to be accurate and reliable. However, Aimtec Inc. assumes no responsibility for the consequences of use of such information nor for any infringement of patents or other rights of third parties which may result from its use. No license is granted by implication or otherwise under any patent or patent rights of Aimtec Inc. Specifications mentioned in this publication are subject to change without notice. This publication supersedes and replaces all information previously supplied. Aimtec Inc. Products are not authorized for use as critical components in life support devices or systems without express written approval of Aimtec Inc.

© 2006 Aimtec Inc. – All Rights Reserved

